

''20'' TRACTOR PARTS LIST

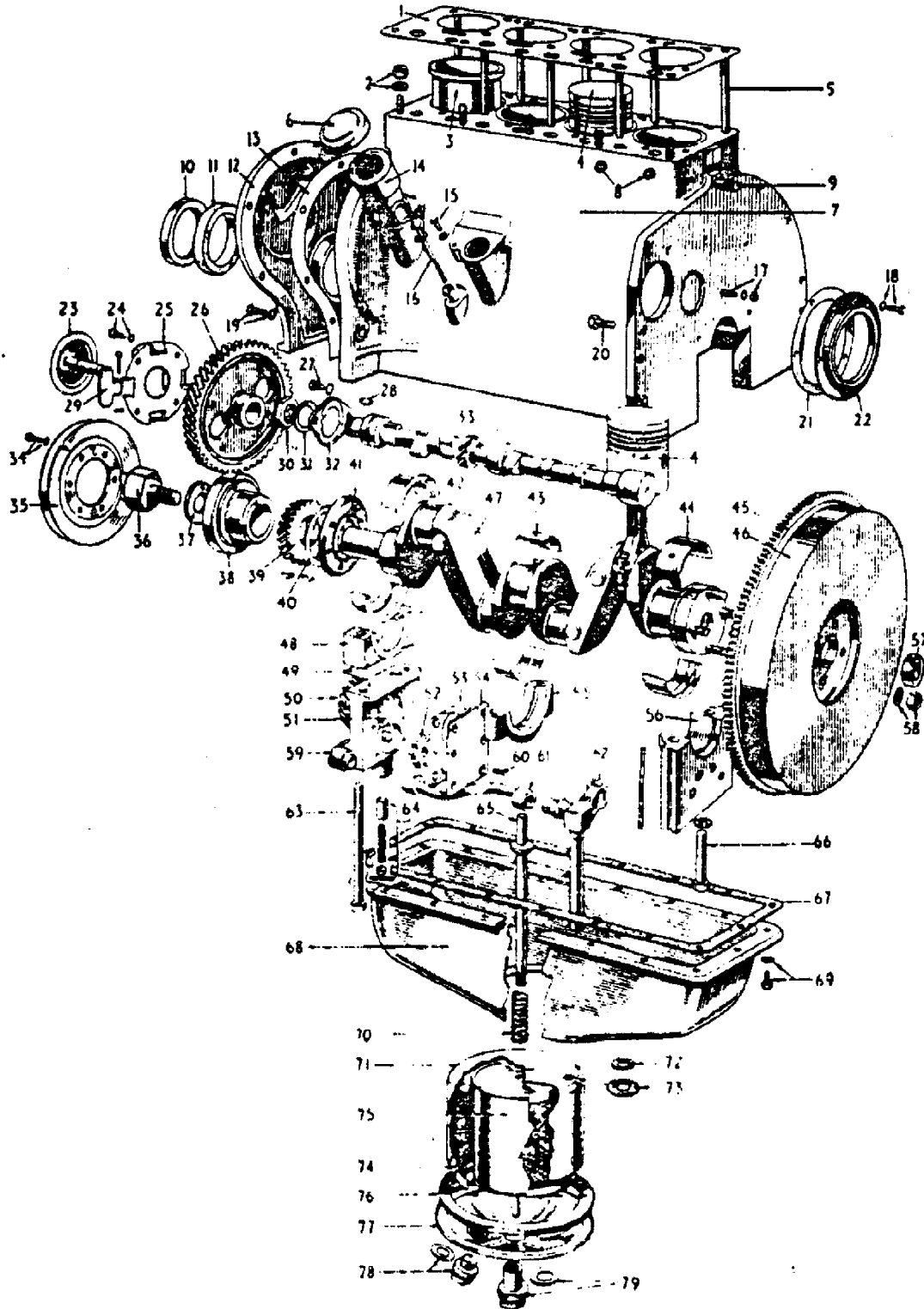

FIG. 35

AGCO Corporation
Parts List Report

Massey Ferguson (Europe)
TE 20 TRACTOR
Page 126 - ENGINE DETAILS - DETAIL

Item	Part Number	Qty	Part Description	Comments
				DETAIL T.E. 20
1	7135	1	Gasket	
2	1628	13	Nut	
	1625	13	Washer	29/44"
	1618	5	Stud	7/16" - 14-20 X 1-13/16"
3	2118	1	Sleeve	
4				See Page/Reference Number 36
5	1626	8	Stud	7/16" - 14-20 X 4-13/16"
6	1754	1	Cap	
7	9576	1	Cylinder	INCL. REF. 2, 5, 8, 40, 48, 55, 56, 63, 66
8	1665	2	Stud	
	353441X1	2	Lock Washer	
9	1609	1	Stud	7/16" 14-20 X 1-11/16"
10	1691	1	Seal	
11	1765	1	Seal	
12	8600	1	Cover	INCL. 8590, 1691, 1778, 1780, 16863X NOT SERVICED SEPARATELY.
			Cover	
	1910	2	Dowel	NOT ILLUSTRATED
	1769	1	Shaft	NOT ILLUSTRATED
	1776	2	Bearing	
	1777	1	Seal	
	1767	1	Seal	
	1768	1	Arm	
	1672	1	Pin	
	1673	1	Pin	5/32 X 1"
	1778	1	Spring	
	1780	2	Washer	
	1779	1	Screw	
	16863X	2	Rivet	
	355564X1	1	Nut Unc	
	2199	1	Spring	
	4242	1	Lever	

13	7134	1	Gasket	
14	4233	1	Filler	
15	353666X1	1	Screw Unc	
	353441X1	1	Lock Washer	
	353754X1	1	Washer	
16	1748	1	Rod	
	1751	1	Washer	
	1752	1	Support	
17	1634	2	Screw	
	2239	2	Gasket	
18	1634	3	Screw	1/4" X 5/8"
	353754X1	3	Washer	
19	1615	1	Screw	
	353692X1	6	Screw Unc	
	353434X1	7	Lock Washer	
20	353696X1	2	Screw Unc	
	353699X1	11	Screw Unc	
	353432X1	4	Lock Washer	
	1609	1	Stud	
	353426X1	1	Nut Unf	
	353757X1	6	Washer	
	353701X1	6	Screw Unc	
	353702X1	5	Bolt Unc	
	353697X1	2	Screw Unc	Alternative
	1608	2	Stud	Alternative
	1609	1	Stud	
	353426X1	1	Nut Unf	
	353432X1	4	Lock Washer	
21	1695	1	Gasket	
	1692	1	Retainer	
22	1781	1	Seal	
23	1773	1	Cup	
24	1670	4	Screw	
	1671	4	Washer	3/16"
25	4243	1	Plate	
26	4212	1	Gear	
27	1630	2	Screw	5/16" - 18 X 1/2"
	WE0608	2	Washer	5/16"
28	1241	1	Key	
29	825156M91	4	Weight	
	825891M1	4	Pin	
	354040X1	4	Pin	
30	1632	1	Nut	
31	1911	1	Washer	
32	1683	1	Plate	
33	8592	1	Camshaft	

34	353665X1	6	Screw Unc	
	353441X1	6	Lock Washer	
35	4240	1	Pulley	
	1666	1	Key	
36	1690	1	Jaw	
37	1633	1	Washer	
38	4239	1	Hub	
39	4213	1	Gear	
	1666	1	Key	
40	1685	1	Plate	
	1686	1	Washer	
	1621	3	Pin	
	1687	AR	Shim	.002"
	1688	AR	Shim	.008"
41	1689	1	Thrower	
42	4245	1	Bearing	
	4245/2	1	Bearing	.020"
	4245/3	1	Bearing	.030"
	0045/4	1	Bearing	.040"
43	4246	1	Bearing	
	4246/2	1	Bearing	.020"
	4246/3	1	Bearing	.030"
	4246/4	1	Bearing	.040"
44	4247	1	Bearing	
	4747/2	1	Bearing	.020"
	4247/3	1	Bearing	.030"
	4247/4	1	Bearing	.040"
45	4222	1	Gear	
46	7139	1	Flywheel Assy.	
47	1637	4	Stud	7/16" - 20 X 1-3/4"
	8593	1	Engine	
48	1676	1	Dowel	
49	1723	AR	Shim	.002"
50	4251	1	Pump	
	1725	1	Pump	
	1735	1	Pinion	
51	4252	1	Body	
	1733	3	Plug	
	1734	1	Stud	
	1727	2	Bush	
52	1726	1	Gear	
53	1730	1	Gasket	
54	1724	1	Cover	
	1648	2	Pin	
55	4215	1	Bearing Cap	
	1684	1	Plug	

	1623	2	Plug
56	7138	1	Bearing Cap
	1747	AR	Packing
57	195174M1	1	Bearing
58	1638	4	Nut
	353432X1	4	Lock Washer
59	1740	1	Elbow
60	1647	6	Screw
61	1729	1	Tube
	1738	2	Sleeve
62	1741	1	Support
	2306	1	Tube
	1739	1	Elbow
63	1616	2	Screw
64	1731	1	Valve
	1744	1	Spring
	1732	1	Retainer
	354061X1	1	Pin
65	1742	1	Tube
66	1617	4	Screw
	1619	6	Washer
67	7142	1	Gasket
68	8596	1	Pan
69	1653	18	Screw
70	1711	1	Spring
71	4232	1	Cover
72	1651	1	Washer
73	1652	1	Washer
74	4231	1	Screen
75	TE.18632-1	1	Element
	TE.18636	1	Liner
76	4228	1	Gasket
77	4229	1	Cover
78	1746	1	Plug
	1655	1	Gasket
79	1745	1	Nut
	1645	1	Gasket
	7135	1	Gasket
	7144	1	Gasket
	1730	1	Gasket
	4224	1	Gasket
	7134	1	Gasket
	7142	1	Gasket
	1677	8	Packing Gland
	4228	1	Gasket
	1691	1	Oil

1695	1	Gasket
4236	1	Gasket
1747	2	Packing
1765	1	Seal
1777	1	Oil
1781	1	Oil
1645	2	Gasket
1655	1	Gasket
1654	1	Gasket
1756	1	Gasket
1767	1	Dust Shield
1651	1	Felt
1652	1	Felt
1751	1	Felt

NOT ILLUSTRATED

1478	1	Union
1659	1	Stud
1660	2	Stud
826773M1	1	Cock
