

"20" TRACTOR PARTS LIST

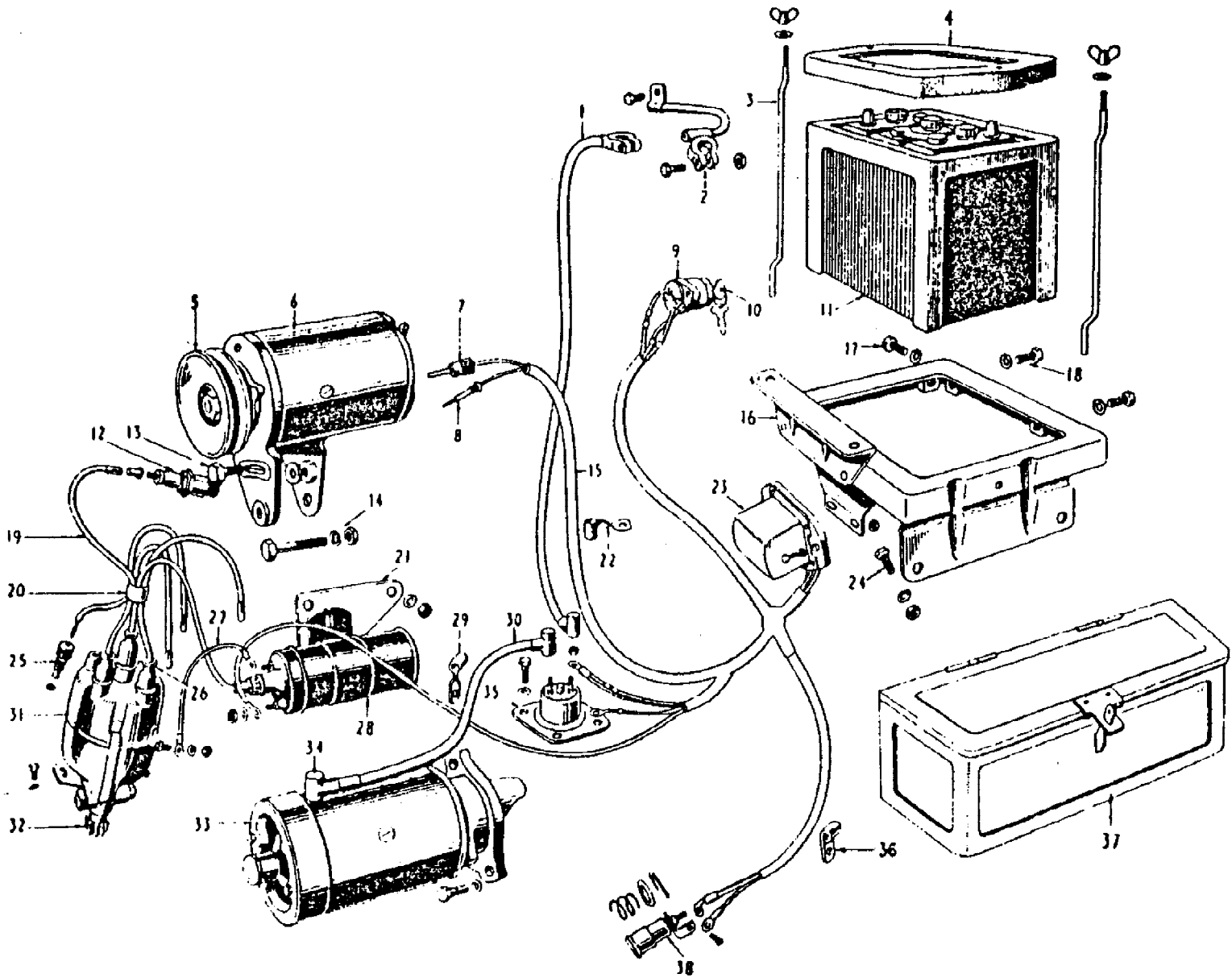

FIG. 31

AGCO Corporation
Parts List Report

Massey Ferguson (Europe)

TE 20 TRACTOR

Page 106 - ELECTRICAL EQUIPMENT COMPLETE WITH WIRING (6 VOLT) - 80 M/M PET, 85 M/M PET

Item	Part Number	Qty	Part Description	Comments
				80 M/M PET, 85 M/M PET 85 M/M V.O., 85 M/M L.O.
1	974374	1	Lead	(A)
2	974373	1	Lead	(A)
	4188033	2	Bolt	(A)
				80 M/M PET.
	4188035	2	Nut	(A)
				80 M/M PET.
	186111	2	Screw	(A)
3	4134	2	Stem	
	826805M1	2	Nut	
	353754X1	2	Washer	
4	7271	1	Frame	
	4392	1	Cover	
5	56837	1	Pulley	(B)
	60561	1	Washer	(B)
	825365M1	1	Pulley	(C)
	825382M1	1	Washer	(C)
6	22420D	1	Dynamo	(A) (B) Alternative
	22256B	1	Dynamo	(A) (C) Alternative
	22261A	1	Dynamo	(A) (C) Alternative
7	238743	1	Plug	(A)
8	238742	1	Plug	(A)
9	31083B	1	Switch	(A)
10	312305	2	Shaft	(A)
11	4010370F	1	Battery	(A)
12		4	Spark Plug	14 MM NOT SERVICED. PURCHASE LOCALLY 80 M/M PET, 85 M/M PET
		4	Spark Plug	14 MM NOT SERVICED. PURCHASE LOCALLY 85 M/M V.O., 85 M/M L.O.
	825394M1	1	Cover	
	825401M1	1	Grommet	

13	353885X1	1	Bolt Unf	80 M/M PET INCL. REF. 21
14	353589X1	1	Bolt Unf	80 M/M PET INCL. REF. 21
15	974361	1	Harness	(A) INCL. REF. 7, 8
16	8565	1	Pedestal	80 M/M PET, 85 M/M PET, 85 M/M VO
	8709	1	Pedestal	85 M/M LO
17	354391X1	2	Screw Unf	
	353432X1	2	Lock Washer	
18	354391X1	2	Screw Unf	
	353432X1	2	Lock Washer	
19	826265M1	1	Wire	
20	941834	3	Cleat	(A)
21	825409M1	2	Screw	
	353918X1	2	Nut Unf	
22	858229	1	Clip	(A)
	1919	1	Clamp	
23	37053E	1	Box	(A)
	353668X1	2	Screw Unc	
	355564X1	2	Nut Unc	
	353441X1	2	Lock Washer	
24	353696X1	2	Screw Unc	80 M/M PET, 85 M/M PET
	355645X1	2	Nut Unc	80 M/M PET, 85 M/M PET
	353432X1	2	Lock Washer	80 M/M PET, 85 M/M PET
	353432X1	2	Lock Washer	(D) 85 M/M VO, 85 M/M LO
	354391X1	2	Screw Unf	(D) 85 M/M VO, 85 M/M LO
	353426X1	2	Nut Unf	(D) 85 M/M VO, 85 M/M LO
	2236	1	Flange	(D) 85 M/M VO, 85 M/M LO
	2237	1	Support	(D) 85 M/M VO, 85 M/M LO
	2398	1	Support	(E) 85 M/M VO, 85 M/M LO
	353502X1	1	Screw Unf	85 M/M VO, 85 M/M LO
	353446X1	1	Lock Washer	85 M/M VO, 85 M/M LO
	353426X1	1	Nut Unf	85 M/M VO, 85 M/M LO
	353708X1	2	Bolt Unc	(E) 85 M/M VO, 85 M/M LO

	353432X1	2	Lock Washer	(E) 85 M/M VO, 85 M/M LO
	355645X1	2	Nut Unc	(E) 85 M/M VO, 85 M/M LO
	2397	2	Distance Piece	(E) 1-1/2" 85 M/M VO, 85 M/M LO
25	410600	5	Nut	(A)
	185015	5	Washer	(A)
26	825822M1	5	Cover	
27	999107	1	Lead	(A)
28	45014A	1	Coil	(A)
29	858229	2	Clip	(A)
30	974372	1	Lead	(A)
31	40243A	1	Distributor	(A) 85 M/M PET
	40146D	1	Distributor	(A) 80 M/M PET
	40186A	1	Distributor	(A) 85 M/M VO
	40229A	1	Distributor	(A) 85 M/M LO
	400935	1	Gauge	
32				Not Serviced, Order 42
33	25519E	1	Starter Clutch	(A)
	60664	AR	Washer	
34	858266	3	Boot Rubber	(A)
35	76418A	1	Starting Switch	(A)
	353675X1	4	Screw Unc	80 M/M PET
	353678X1	4	Screw Unc	
	353755X1	4	Washer	
	1300	1	Lever	
	1301	1	Link	
	195234M1	1	Clevis Pin	
	353755X1	1	Washer	
	31PS50B	1	Pin	
	31PS156B	1	Pin	
	354046X1	3	Pin	
36	187081	1	Clip	(A)
37	825633M91	1	Tool Box	
	827435M1	1	Wrench	5/16" & 1/2"
	825799M1	1	Spanner	
	827432M1	1	Bar	
	827433M1	1	Spanner	7/16"
	827436M1	1	Wrench	7/16" & 3/8"
	1850685M91	1	Gun	
	4164	1	Handle	
	2643	1	Retainer	
38	38029B	1	Light	(A)
				NOT ILLUSTRATED
	404965	1	Cover	(A)

974371	1	Cable	(A) INCL. REF. 1, 2, 30
829700	1	Harness	(A) INCL. REF. 1, 2, 15, 27, 30
354403X1	2	Bolt	80 M/M PET, 85 M/M PET, 85 M/M VO
354403X1	1	Bolt	85 M/M LO
353432X1	2	Lock Washer	
4309	1	Mat	80 M/M PET, 85 M/M PET, 85 M/M VO
4309	2	Mat	85 M/M LO
2201	2	Clamp	(F) 80 M/M PET, 85 M/M PET, 85 M/M VO
2201	1	Clamp	85 M/M LO
2202	2	Clamp	(F) (A) SERVICED BY MESSRS. J. LUCAS LTD. (B) Up to Serial or Engine Number 132,205 (C) From Serial or Engine Number 132,206 (D) Up to Serial or Engine Number 124,635 (E) From Serial or Engine Number 124,636 (F) From Serial or Engine Number 101678
